

User Manual



GLOW STREAM™ **HD**

©2020-2021 Glow Stream LLC. All rights reserved. This publication nor any portion thereof may not be reproduced or used in any manner whatsoever without the express written permission of the publisher.

Glow Stream™ is a trademark of Glow Stream LLC. NDI® is a registered trademark of NewTek, Inc. vMix® is a registered trademark of StudioCoast Pty Ltd. Windows® is a registered trademark of Microsoft Corporation.

Every effort was made to ensure that the information contained in this user guide was accurate at the time of publication. However, the publisher has no control over third-party software or websites referenced herein, and changes to such software and websites after the date of publication may render these instructions inaccurate.

Glow Stream™ cameras are sold for use in the United States. Any use of Glow Stream™ products outside the United States voids any warranty in effect, and after-sale support is not available outside the United States.

Glow Stream™ HD User Manual v1.0.3 (May 2021)

Read this first

Before operating the unit, please read this manual thoroughly, and retain it for future reference.

CAUTION

Local regulations

Please follow all local regulations and ordinances when installing and using this camera.

Electrical safety

Please follow all proper electrical safety precautions when installing and operating this camera.

Power supply voltage and polarity

The camera requires 12V of DC power, with a maximum current of 2 Amps. The polarity is shown in the drawing to the right. The camera may also be powered via the ethernet port by connecting to a network switch with Power-over-Ethernet capabilities.

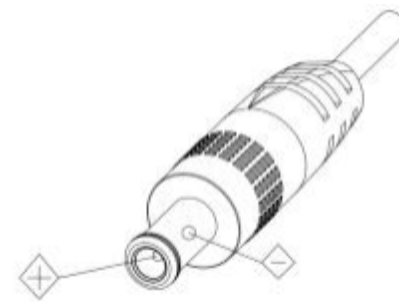

Use care

- When installing and using this camera, avoid excess stress, vibration and moisture.
- Do not install or use this camera near water.
- Do not install near any heat sources such as radiators, heat registers, stoves, or other apparatus (including amplifiers) that produce heat.

- Never move the camera head by hand. This can damage the camera and prevent it from being panned or tilted by remote control.
- Install only on a smooth horizontal surface. Do not attempt to install on an angled surface.
- When installing on the wall or ceiling, use only the manufacturer's mounting bracket.
- Make sure there are no obstacles in the rotation range.
- Disassembling the camera may damage it and will void the manufacturer's warranty.
- Do not power on until installation is complete.
- Unplug the camera during lightning storms or when unused for long periods of time.

Electromagnetic interference

Using this camera in the presence of a strong electromagnetic field may affect the camera image, and can damage the electronics.



Warning: Follow all instructions carefully when installing and using this camera. Any use of this camera outside these instructions may damage it and void the manufacturer's warranty.

Contents

Read this first	1
CAUTION.....	1
Use care.....	1
Contents.....	3
Getting Started.....	7
Camera Hardware	7
Included Items.....	8
Power on and initial configuration.....	8
Video Output	9
NDI Video Output.....	9
HDMI Video Output	9
3G-SDI Video Output.....	9
Camera Operations.....	9
Remote Control.....	9
1. Infrared Remote.....	10
2. Web Browser.....	10
3. PTZ Controller	11
4. Broadcast Software.....	11
5. Mobile App.....	11
Camera Features.....	11
Technical Specifications	14
Remote Controller	17
Camera Control.....	19

Camera Selection.....	20
Pan/Tilt Control.....	20
Zoom	21
Focus.....	21
Backlight Compensation Setting	22
Setting/Clearing Presets	22
Camera Remote Controller Address Setting	23
Menu Settings	23
Main Menu.....	24
(Setup) System Settings	24
(Camera) Camera Settings	25
(Exposure) Exposure Settings	25
(Color) Color Settings.....	26
(Image) Image Settings	27
(Focus) Focus Settings.....	29
(Noise Reduction) Noise Reduction Settings	29
(P/T/Z) Pan, Tilt, Zoom settings	30
Network Connection	31
Connecting to the Network.....	31
Alternate Direct Connection.....	31
Setting the camera's IP address.....	32
Prepare computer to access camera.....	32
Use web browser to access camera	34
Set the camera's IP address.....	35
Return computer's IP address to previous setting	36
Test the NDI connection (optional).....	36
Web Client.....	38
Web client Log In	38

Download and Install Plug-in	39
Preview	40
Recording	40
Playback.....	40
Configuration	41
Local Configuration	42
Audio Configuration.....	42
Video configuration.....	43
Video encoding.....	43
Stream Release	44
RTP Broadcasting.....	44
Video Parameters.....	45
Character-Overlapping.....	47
Character Size.....	48
Video output.....	48
Network configuration.....	48
Network port	48
Ethernet parameters.....	49
DNS parameters.....	49
GB28181	49
System configuration.....	49
Device Properties	49
System Time	50
User Management.....	50
Version upgrade.....	51
Restore factory setting.....	52
Reboot	52
Logout	52

External Interfaces	53
Bottom Dial Switch	54
RS-232 Interface	55
RS-232 Mini-DIN 8-Pin Port Definition	56
RS-232 DB9 Port Definition	56
Visca Daisy-Chain Example	57
Serial Communication Control.....	57
VISCA protocol list.....	58
Camera return command	58
Camera control command	59
Pelco-D protocol command list	68
Pelco-P protocol command list.....	69
Maintenance	70
Troubleshooting	71
My camera won't power on.....	71
My computer won't connect to the camera	71
Sometimes there is no image.....	71
Image shakes when zooming in or out.....	72
Remote control does not work	72
Serial port does not work.....	72
There is high latency in vMix	73
The video freezes when using the NDI stream	73
How much bandwidth does NDI HX use?.....	73
Limited Warranty.....	74

Getting Started

Camera Hardware

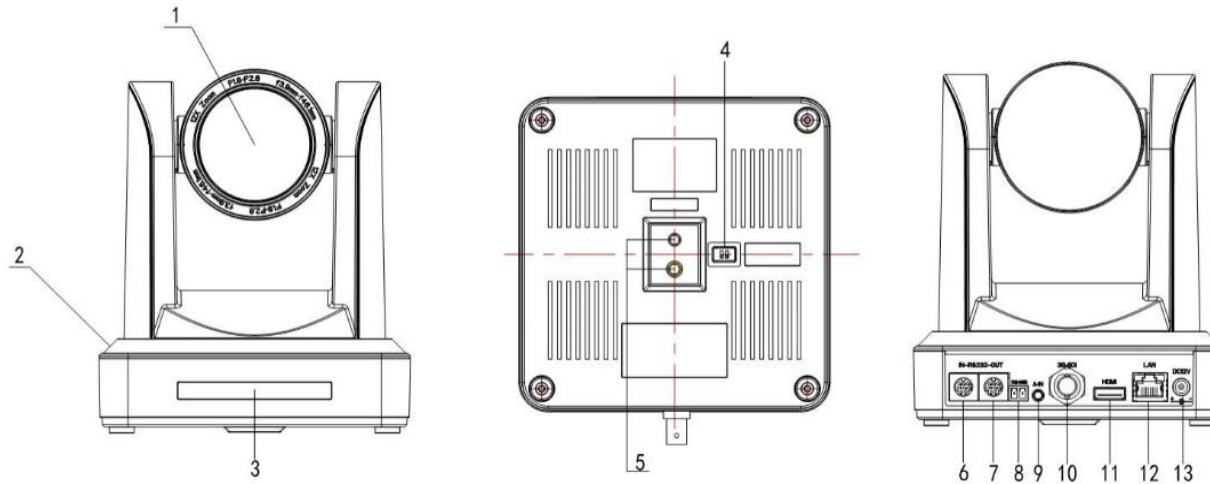

Figure 1.1: Parts of the Camera

- | | | |
|-----------------------------------|--------------------------------------|--|
| 1. Camera Lens | 6. RS232 Control Interface (input) | 10. 3G-SDI Interface |
| 2. Camera Base | 7. RS232 Control Interface (output) | 11. HDMI Interface |
| 3. Infrared Remote Receiver Light | 8. RS485 Input (left +,right-) | 12. 10/100 Network Interface Ethernet Port |
| 4. Bottom Dial Switch | 9. Audio Input Interface | 13. DC 12V Input Power Supply Socket |
| 5. Tripod Screw Hole | | |

Included Items

The following items are included in the box:

- Glow Stream™ HD camera
- DC 12V power adapter
- Ethernet crossover cable
- Infrared remote controller
- User Manual
- Quick Start Guide
- Warranty card

Power on and initial configuration

Plug an ethernet cable into a network switch with Power-over-Ethernet (PoE), or connect the DC12V power supply adapter to the camera with power supply socket.

When you power on the camera the power indicator light and remote control receiver light will blink. The camera head will move for a few seconds, then return to the home position (horizontal and vertical intermediate position). When the remote control receiver light stops blinking, the self-check is finished and the camera is ready for use.



Note: If you set a camera position for Preset 0 (see page 22), when the power-on self-test is completed the camera will automatically move to the Preset 0 position.

Video Output

Your Glow Stream™ camera can output video via **NDI, HDMI** and **3G-SDI**.

NDI Video Output

Connect an ethernet cable to the network interface port marked NDI on the camera (number 12 in the diagram on page 7). An NDI video signal will automatically be broadcast over the network, which can be accessed using any device that accepts NDI input.

HDMI Video Output

Connect the HDMI video cable to the HDMI port on the camera (number 11 in the diagram on page 7). Plug the other end of the cable into a monitor or video switcher input.

3G-SDI Video Output

Connect a coax cable with a BNC connector to the 3G-SDI port on the camera (number 10 in the diagram on page 7). Connect the other end to a monitor or video switcher input.

Camera Operations

Remote Control

Panning, tilting, zooming, focusing and other camera operations can be controlled remotely using any of five different methods:

1. Infrared Remote

An infrared remote control device is included with the camera. (See page 17 for detailed instructions on how to use the remote.)

2. Web Browser

Connect to the camera using a web browser on any device on the same local area network as the camera.

To configure the camera open your web browser and enter **192.168.5.163** (factory default) in the URL address bar and press Enter.



Note: If the network settings of the camera have previously been configured, the IP address is probably different. See page 37 for instructions on finding the current IP address of the camera.

Enter the factory default user name **admin** and password **admin** and press Enter. You can use the web interface to control pan, tilt and zoom of the camera, start and stop video recording, and configure the camera.

(See page 31 for detailed instructions on how to set up the camera on your network, control the camera and change its settings.)

3. PTZ Controller

Connect a hardware PTZ controller to the network to control the camera using IP Visca or ONVIF protocols. Or connect it directly via the RS232 or RS422 port to control it with Visca, Pelco-P or Pelco-D protocols. (See detailed connector specifications and protocol definitions beginning on page 55.)

4. Broadcast Software

The camera can be controlled from many of today's most popular broadcast video programs, including vMix, OBS, Wirecast, TriCaster and Livestream Studio. See the instructions for your specific software for connecting and controlling a camera using Sony's IP Visca PTZ protocol.

Some basic instructions for connecting to vMix and OBS may be found in the separate NDI Quick Start Guide, provided with your Glow Stream™ camera.

5. Mobile App

There are several mobile apps available for either iOS or Android devices using either ONVIF or IP Visca to control a camera on the same local area network as the mobile device. Search for "ONVIF" or "IP Visca" in the app store for your device to see currently available options.

Camera Features

This Glow Stream™ camera offers an excellent image quality through a variety of interfaces. The features include advanced ISP processing algorithms to provide vivid images with a strong sense of depth, high

resolution and fantastic color. It supports H.265/H.264 encoding which makes motion video fluent and clear even with less than ideal bandwidth conditions.

Superb high-definition image. This camera employs a 1/2.8 inch high-quality CMOS sensor. Resolution can be up to 1920x1080 with frame rate up to 60 fps.

Optical zoom lens. Depending on the model, this camera has a 12X, 20X or 30X optical zoom lens.

Leading auto-focus technology. Glow Stream's auto focus algorithm makes the lens fast, accurate and stable when auto-focusing.

Low noise and high signal-to-noise ratio. The camera has a low-noise CMOS ensuring a high signal-to-noise ratio of the camera video. Advanced 2D/3D noise reduction technology is also used to further reduce the noise, while ensuring image sharpness.

Quiet camera movement. The camera uses a high-accuracy step-driving motor mechanism which is extremely quiet, moving smoothly and quickly to the designated position.

Multiple video outputs. This camera supports HDMI, 3G-SDI, and NDI via a wired ethernet port. The 3G-SDI is available for 100m transmission at 1080p60 format.

Low-power sleep function. This camera has a low-power sleep/wake up feature. It will go into sleep mode when the power is lower than 500mW.

Multiple control protocols. This camera supports VISCA, PELCO-D, PELCO-P protocols which are automatically recognized. The IP VISCA and ONVIF control protocols also supported through the network interface.

RS-232 cascade function. This camera supports RS-232 cascade functionality, which permits daisy-chaining of multiple cameras via the RS-232 port.

255 preset positions. There are 255 presets available using the web interface, the first 10 of which are also available on the remote control.

Wide application use. The camera may be used for live streaming, tele-education, lecture recording, webcasting, videoconferencing, tele-training, tele-medicine, interrogation and emergency command systems.

Multiple compression protocols. The camera supports 16,000, 32,000, 44,100, and 48,000 audio sampling rates and AAC, MP3, and PCM audio encoding. It supports H.264/H.265 video compression and resolution up to 1920x1080 with up to 60 frames per second.

Multiple network protocols. Supports ONVIF, RTSP and RTMP protocols, and RTMP push mode.

Technical Specifications

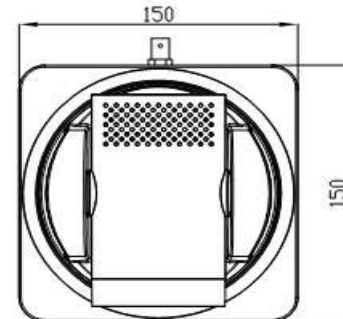
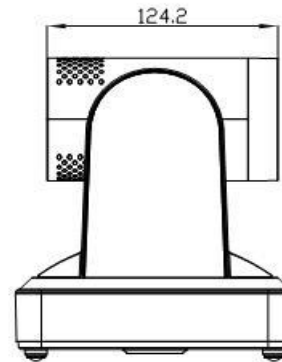
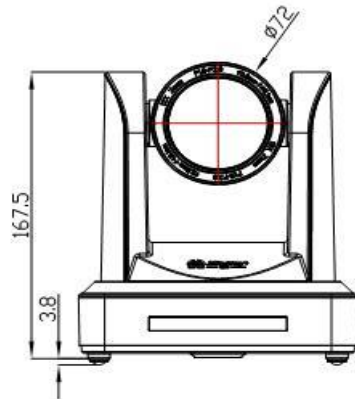
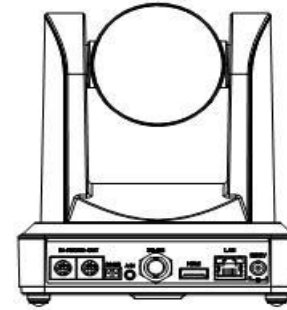
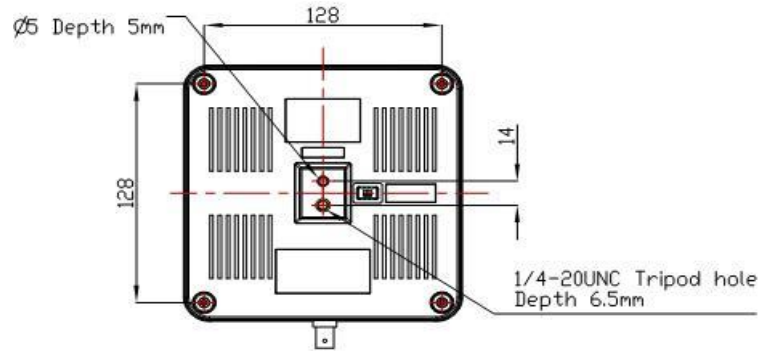

Model	GS300-12x-NDI	GS300-20x-NDI	GS300-30x-NDI
Camera	1/2.8" CMOS		
Image sensor	1920 x 1080 pixels, 1280 x 720 pixels		
Video resolution	60, 50, 30, 25, 59.94, or 29.97 frames per second		
Frame rate	2.07 megapixel		
Effective pixels	12x (3.9mm ~ 46.8mm) f1.8-f2.4	20x (5.2mm ~ 98mm) f1.6-f3.5	30x (4.3mm ~ 129mm) f1.6-f4.7
Optical zoom	5x, 10x, 12x, 20x, 30x		
Aperture	0.5Lux (F1.8, AGC ON)		
Digital zoom	2D & 3D DNR		
Minimum Illumination	Auto / Manual / One Push/ 3000K / 4000K / 5000K / 6500K		
DNR	Auto/Manual		
White Balance	Auto/Manual		
Focus	Auto/Manual		
Aperture	ON/OFF		
Electronic Shutter	OFF / Dynamic level adjustment		
BLC	Brightness, Color, Saturation, Contrast, Sharpness, B/W mode, Gamma curve		
WDR	>55dB		
Video adjustments			
Signal-to-noise ratio			
I/O interfaces			
Ports	HDMI, 3G-SDI, RJ45 ethernet, Audio-in, RS232 (in & out), RS485		
Video interface	HDMI, 3G-SDI, NDI HX 4.0		
Image code stream	Double streams outputs simultaneously		
Video compression	H.264, H.265		
Control signal interface	RS-232 Ring through RS232 output, RS-485		
Control protocol	VISCA/Pelco-D/Pelco-P		
Control baud rate	115200/9600/4800/2400bps		
Audio input	Double track 3.5mm linear input		

Model	GS300-12x-NDI	GS300-20x-NDI	GS300-30x-NDI
Audio compression Ethernet interface Network protocols Power interface	AAC/MP3/PMC Audio compression 100Mbps (100BaseT), supports IP Visca control protocol RTSP/RTMP, ONVIF, NDI HX 4.0 HEC3800 outlet (DC12V)		
PTZ Parameters Pan Rotation Tilt Rotation Pan Control Speed Tilt Control Speed Preset Pan Speed Preset Tilt Speed Preset limit	±170° -30° ~ +90° 0.1-180°/sec 0.1-80°/sec 60°/sec 30°/sec 255 presets (10 presets by remote controller)		
Other Power Supply Adapter Input Voltage Input Current Consumption Storage Temperature Storage Humidity Working Temperature Working Humidity Dimension Weight Working Environment Remote Operation (IP)	AC 110V-220V to DC 12V/2A DC12V ±10% 1 amp max 12 watts max 10°F to 140°F (-10°C to +60°C) 20% - 95% 10°F to 120°F (-10°C to +50°C) 20% - 80% 5.9" x 5.9" x 6.6" (150mm x 150mm x 167.5mm) 3.1 lbs (1.4 kg) Indoor Remote Upgrade, Reboot and Reset		

Remote Controller

Power button: Press Power for 3 seconds, and the camera will go into standby mode. Press it again for 3 seconds, and the camera will perform a self-test and go back to its HOME position. (Note: If power-on mode is turned on and Preset 0 is set, and there is no operation within 12 sec, it will automatically move to the specified preset position.)

CAMERA SELECT: Select the camera to be controlled.

Number Keys: Press 0-9 to set or run presets.

*** and # Keys:** Used for key combinations.

Auto Focus: Press **[AUTO]** to set the camera to auto focus mode.

Manual Focus: Press **[MANUAL]** to set the camera to manual focus mode.

Switch the camera focus mode to manual focus by pressing **[FOCUS +]** or **[FOCUS -]** to adjust.

[Zoom +]: Zoom lens out to see subject closer up

[Zoom -]: Zoom lens in to see subject farther away.

Set Preset: Press **[SET PRESET]** then a numeric key

Clear Preset: Press **[CLEAR PRESET]** then a numeric key

Pan/Tilt Controls: Press any of the arrows to pan or tilt the camera in that direction.



HOME: Press **HOME** to return the camera to the middle position or open the next level menu.

BLC ON/OFF: Press **[BLC ON/OFF]** to turn the backlight on or off.

Menu: Press **MENU** to open or close the on-screen display menu or return to the previous menu.

Camera IR Remote Control Address

- **Camera Address 1**
Press [*] [#] [F1]
- **Camera Address 2**
Press [*] [#] [F2]
- **Camera Address 3**
Press [*] [#] [F3]
- **Camera Address 4**
Press [*] [#] [F4]

Key Combination Functions: Press the indicated keys in succession to perform the function.

Clear all presets: [#] [#] [#]

Restore factory defaults: [*] [#] [6]

Restore the default user name, password, and IP address: [*] [#] [Manual]

Flip switch: [*] [#] [9]

Auto: Enter into the aging mode: [*] [#] [+]

Set menu to Chinese: [*] [#] [3]

Set menu to English: [*] [#] [4]

Switch the video format to 1080P60: [#] [#] [0]

Switch the video format to 1080P50: [#] [#] [1]

Switch the video format to 1080I60: [#] [#] [2]

Switch the video format to 1080I50: [#] [#] [3]

Switch the video format to 720P60: [#] [#] [4]

Switch the video format to 720P50: [#] [#] [5]

Switch the video format to 1080P30: [#] [#] [6]

Switch the video format to 1080P25: [#] [#] [7]

Switch the video format to 720P30: [#] [#] [8]

Switch the video format to 720P25: [#] [#] [9]

Camera Control

When the camera is finished initializing, it can receive and execute the IR commands. When a key is pressed, the indicator light flashes; when the key is released, the indicator light stops flashing. Users can control the Pan, Tilt, Zoom and Presets via the IR remote control.

Key Instructions:

- “Press the key” means a simple press of the key rather than a long-press. A beep will be heard if a long-press required.
- When a key-combination is required, press the keys in the exact sequence. For example, [*] [#] [F1] means to press [*] first and then press [#], then press [F1].

Camera Selection



Select the camera address to control.

Pan/Tilt Control



Up: Press [▲]

Down: Press [▼]

Left: Press [◀]

Right: Press [▶]

Back to middle position: press **[HOME]**

Pressing and holding the ▲ / ▼ / ◀ / ▶ key will produce continuous action until the key is released.

Zoom

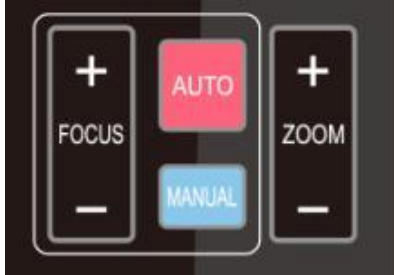

ZOOM IN: Press **[ZOOM +]**

ZOOM OUT: Press **[ZOOM -]**

Pressing and holding the key will continue the action until the key is released.

Focus

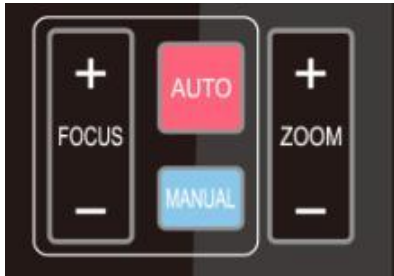

Auto Focus: Press **[AUTO]** to set the camera to auto focus mode.

Manual Focus: Press **[MANUAL]** to set the camera to manual focus mode.

Focus (near): Press the **[FOCUS +]** key (Valid only in manual focus mode)

Focus (far): Press the **[FOCUS -]** key (Valid only in manual focus mode)

Pressing and holding the +/- key will continue the action until the key is released.

Backlight Compensation Setting



BLC ON / OFF: Press **[BLC ON/OFF]** to toggle the backlight compensation on and off.

Setting/Clearing Presets



Set a Preset: Press **[SET PRESET]**, then press the number (0-9) key to set. There are 10 preset positions available.

Run a Preset: Press a number key 0-9 to run the stored preset actions. If there is no preset actions set for the number, nothing will happen.

Clear a Preset: Press **[CLEAR PRESET]**, then press the number (0-9) key to clear.

Clear All Presets: Press the **[#]** key three times to cancel all presets.



Camera Remote Controller Address Setting



Camera Address 1

Press [*] [#] [F1]

Camera Address 2

Press [*] [#] [F2]

Camera Address 3

Press [*] [#] [F3]

Camera Address 4

Press [*] [#] [F4]

Menu Settings

Press **[MENU]** to display the menu. Use the up [▲] and down [▼] arrows to highlight the menu items.

Use the left [◀] and right [▶] arrows to change the values for the menu item. Menu items enclosed in parentheses () will open a secondary menu.

Press **[HOME]** to select a setting.

Press **[MENU]** to go back.

Main Menu

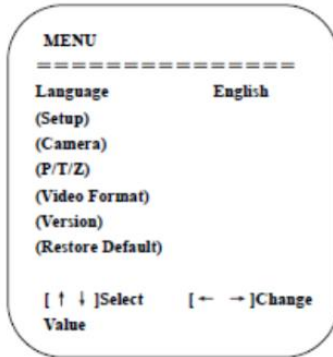

Language: Set language to English or Chinese.

Setup: Enter the System Settings menu.

Camera: Enter the Camera Settings menu.

P/T/Z: Enter the Pan, Tilt, Zoom Settings menu.

Video Format: Enter the Video Format Settings menu.

Version: View the camera version.

Restore Default: Reset the camera to factory default settings.

(Setup) System Settings

Move the pointer to **(Setup)** in the Main Menu then click [HOME] to enter into the System Settings menu.

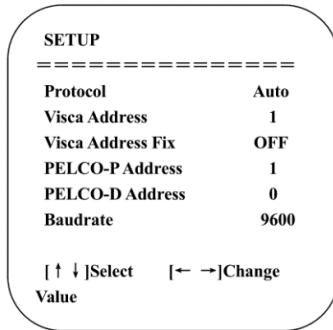

Protocol: Select from VISCA/Pelco-P/Pelco-D/Auto

Visca Address: Select from VISCA 1-7

Visca Address Fix: Set to ON/OFF

Pelco-P Address: Select from 1-255

Pelco-D Address: Select from 1-255

Baud rate: Select from 2400/4800/9600/115200

(Camera) Camera Settings

Move the pointer to **(Camera)** in the Main Menu then click **[HOME]** to enter the camera settings menu.

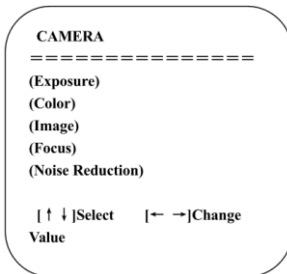

(Exposure): Enter the Exposure settings menu.

(Color): Enter the Color settings menu.

(Image): Enter the image settings menu.

(Focus): Enter the focus settings menu.

(Noise Reduction): Enter the noise reduction settings menu.

(Exposure) Exposure Settings

Move the pointer to (Exposure) in the Menu then click [HOME] to enter the exposure menu.

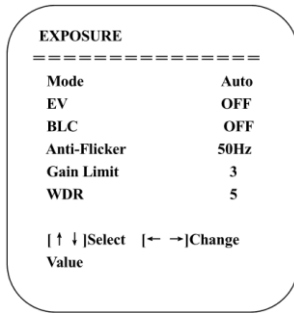

Mode: Select a mode from:

- Auto
- Manual
- Shutter priority: Choose a setting between 1/25 and 1/10,000 (only available in Manual and Shutter priority mode)
- Iris priority: Choose an f-stop setting between F1.8 and F11.0 (only available in Manual and Iris priority mode)
- Brightness priority: Choose a setting 0-23 (only available in Brightness priority mode)

EV: Set to ON/OFF (only available in auto mode)

Compensation Level: -7-7

(only available in auto mode when EV is ON)

BLC: Set to ON/OFF (only available in auto mode)

Anti-Flicker: Set to OFF/50Hz/60Hz

(only available in Auto/Iris priority/Brightness priority modes)

Gain Limit: Set to 0-15

(only available in Auto/Iris priority/Brightness priority mode)

WDR: Set to Off,1-8

(Color) Color Settings

Move the pointer to (Color) in the Menu then click [HOME] to enter the color menu.

COLOR	
WB Mode	Auto
Saturation	80%
Hue	7
AWB Sensitivity	High
Color style	Default
Color temp	Low
[↑ ↓]Select [← →]Change Value	

WB Mode: Set white balance to Auto, 3000K, 3500K, 4000K, 4500K, 5000K, 5500K, 6000K, 6500K, 7000K, Manual, or One Push.

- **Red Gain:** Set to 0-255 (only available in Manual mode)
- **Blue Gain:** 0-255 (only available in Manual mode)

Saturation: Set to 60%, 70%, 80%, 90%, 100%, 110%, 120%, 130%

Hue: Set to 0-14

AWB Sensitivity: Set to High/Middle/Low

Color style: Set to Default, style1-4

Color temp: Set to High/Middle/Low

(Image) Image Settings

Move the pointer to **(Image)** in the Menu then click [HOME] to enter the image menu.

IMAGE	
=====	
Brightness	6
Contrast	8
Sharpness	7
Flip-H	OFF
Flip-V	OFF
B&W-Mode	Color
Gamma	Default
DZoom	OFF
DCI	Close
[↑ ↓]Select	[← →]Change
Value	

Brightness: Set to 0-14

Contrast: Set to 0-14

Sharpness: Set to 0-15

Flip-H: Set to ON/OFF

Flip-V: Set to ON/OFF

B&W Mode: Set to Color or Black/White

Gamma: Set to Default, 0.47, 0.50, 0.52, 0.55

DZoom: Set digital zoom options to ON/OFF

DCI: Set dynamic contrast to OFF, 1-8

(Focus) Focus Settings

Move the pointer to **(Focus)** in the Menu then click [HOME] to enter the focus menu.

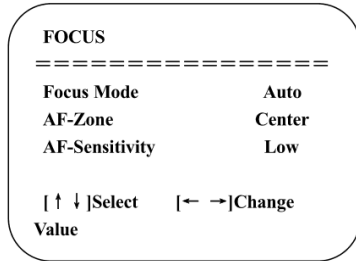

Focus Mode: Set to Auto/Manual

AF-Zone: Set to Up/Middle/Down

AF-Sensitivity: Set to High/Middle/Low

(Noise Reduction) Noise Reduction Settings

Move the pointer to (Noise Reduction) in the Menu then click [HOME] to enter the noise reduction menu.

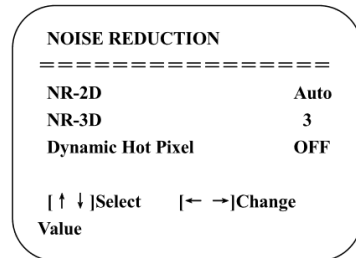

NR-2D: Set 2D Noise Reduction Auto/Close/1-7

NR-3D: Set 3D Noise Reduction to Close/1-8

Dynamic Hot Pixel: Set to Close/1-5

(P/T/Z) Pan, Tilt, Zoom settings

Move the pointer to (P/T/Z) in the Main Menu then click [HOME] to enter the P/T/Z menu.

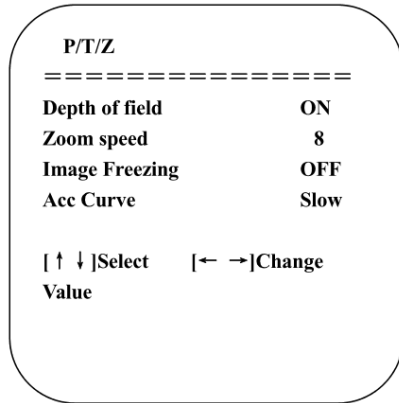

Depth of Field: Set to ON/OFF; When Zoomed in, the PT control speed, when using the remote control will become slow. Only works with the remote control.

Zoom speed: Set the zoom speed for remote control from 1-8.

Image Freezing: Set to ON/OFF.

Acc Curve: Set the speed for easing in/out camera movement.

Network Connection

Connecting to the Network

Using an ethernet cable, plug the camera into a network switch with Power-over-Ethernet. PoE will power the camera without using any other power adapter. **If successful, the orange network light will illuminate and the green light will start flashing.**

Connect your computer to the same network , as shown in the diagram to the right.

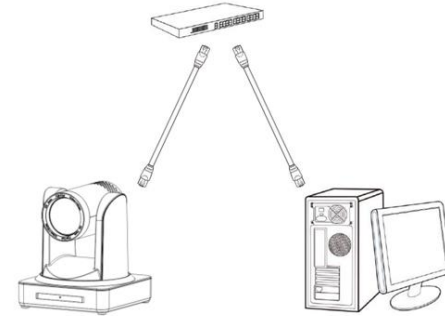

Most low-cost network switches do not have Power-over-Ethernet capability. If your switch does not have PoE, you'll need to use the provided DC power adapter to power the camera.

Alternate Direct Connection

If you do not have a network switch available, alternatively you can connect the camera directly to a computer using the provided ethernet crossover cable, as shown in the diagram to the right.





A **crossover cable** is a special type of ethernet cable used to connect two devices directly, without using a network switch. A standard ethernet cable will not work for this purpose. **A crossover cable is included with your camera.**

Setting the camera's IP address

Once your camera and computer are connected, either through a network switch or directly with a crossover cable, you should set your camera's IP address to something compatible with your network.

Your camera's default IP address is 192.168.5.163. To use the camera on a network, must change this to another address within your network's IP address range.

Prepare computer to access camera

First, you must change the computer's network settings to match the camera, in order to access the camera's settings from the computer. In Windows 10:

1. Open the Network Status window.
2. Under the Advanced Network Settings section, click Change Adapter Settings.

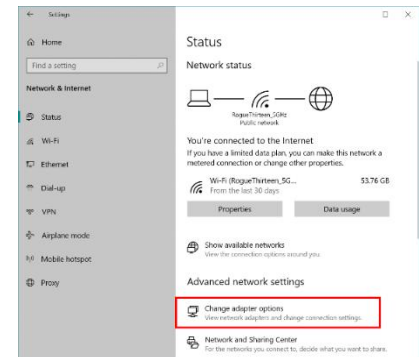

3. Right click the network adapter connected to the camera, and select Properties.

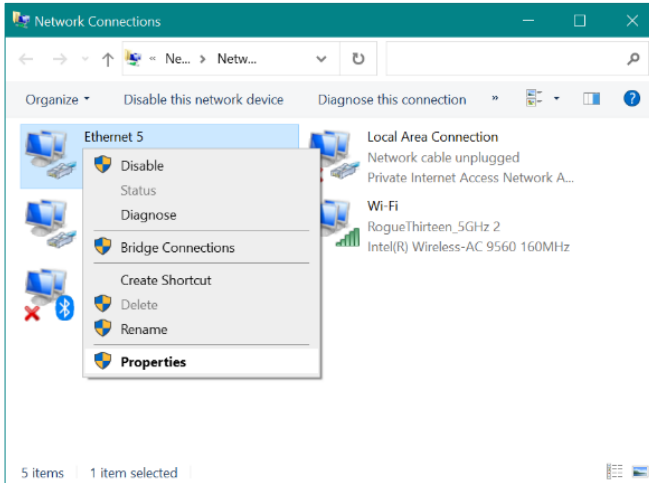

4. Double click the property Internet protocol version 4 (TCP/IPv4).

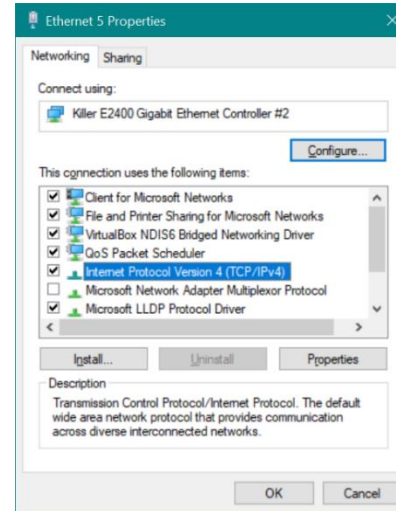

Tip: In the Internet Protocol Version 4 (TCP/IPv4) Properties window, before you make any changes write down the current settings, so they can be restored in a later step below.

5. In the Internet Protocol Version 4 (TCP/IPv4) Properties window, click the Alternate Configuration tab, then set the IP address to **192.168.5.10** and the Subnet mask to **255.255.255.0**. Uncheck "Validate settings, if changed, upon exit" and click OK.

Use web browser to access camera

Open the web browser of your choice and in the address bar enter the default IP address of the camera:

IP Address: **192.168.5.163**

Then log in to the camera with the following default values:

User Name: **admin**

Password: **admin**

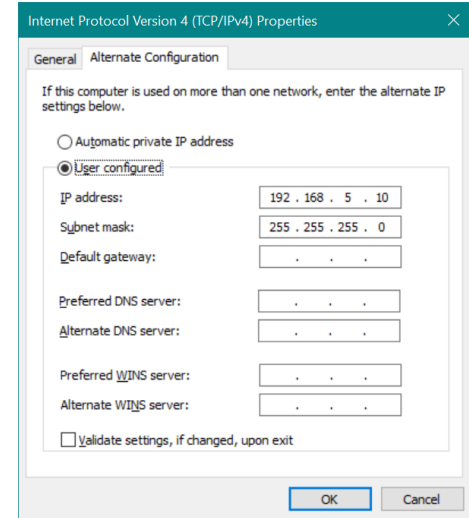



Tip: If the camera's IP address has been changed and you want to reset it, this can be done using the infrared remote. This will also reset the username and password. Press these buttons in this sequence: * # [MANUAL]

Set the camera's IP address

Once you're logged in, go to the ethernet configuration settings to set the IP address:

1. Click Configuration in the top right of the screen.
2. Click Ethernet on the left-hand menu.
3. Enter the IP Address, Subnet Mask, and Default Gateway for your network.

The screenshot shows the camera's configuration interface. At the top right, there are two tabs: 'Preview' and 'Configuration'. The 'Configuration' tab is selected and highlighted with a red box and the number '1'. On the left side, there is a 'Configurations' menu with various options. 'Ethernet' is selected and highlighted with a yellow background and a red box, with the number '2' next to it. The main area displays the 'Ethernet' configuration page. It has a 'DHCP' checkbox which is unchecked. Below it are four input fields: 'IP Address' (192.168.5.115), 'Subnet Mask' (255.255.255.0), 'Default Gateway' (0.0.0.0), and 'MAC Address' (E4:77:D4:05:E8:9A). These fields are grouped by a red box with the number '3'. At the bottom of the form is a 'Save' button.

Or check DHCP if you would like the IP address automatically assigned.



Tip: Using DHCP offers compatibility with most networks, because the assignment of IP addresses is handled by the network's DHCP server. This reduces the potential for conflicting IP addresses.



Warning: If you use DHCP, you will not be able to access to camera via the web browser until you have identified the assigned IP address. This can be done using NDI Studio Monitor (see below), or with software such as Advanced IP Scanner.

Return computer's IP address to previous setting

Once the camera's IP address has been set, you'll want to return the computer's IP address back to its original setting. Follow the sequence described in Step A of this section, and restore the settings you wrote down earlier.

Test the NDI connection (optional)

Before continuing, you may want to confirm that the camera is sending NDI signal and that the computer can access it. The best tool for this is NDI Studio Monitor, from NewTek, available at <https://ndi.tv/tools>.

1. Open the Studio Monitor program.

2. In the upper left, click the menu icon and select the camera.
3. When you mouse over the window, various controls appear for panning, tilting, zooming, and focusing the camera. You can also store camera positions for later recall.
4. Click the gear icon in the lower right to open the camera settings in a browser window. **This shows you the new IP address of the camera in the address bar.**

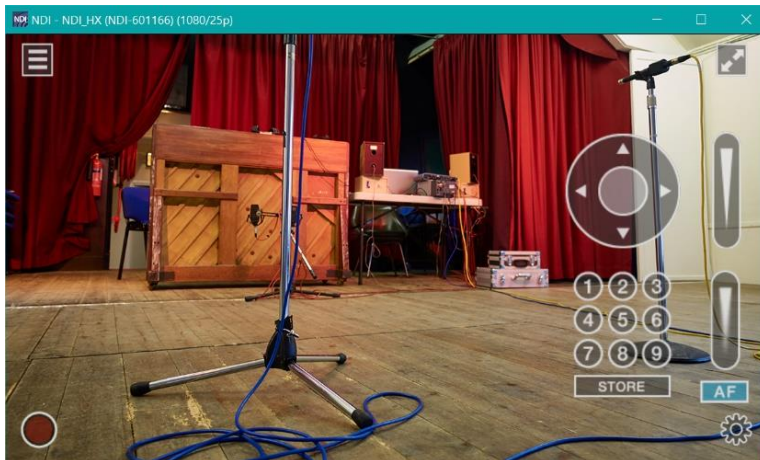
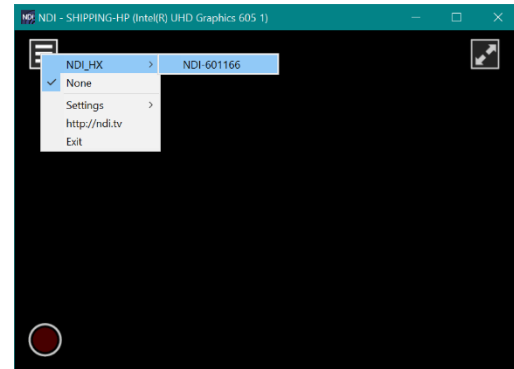

Web Client

Your Glow Stream™ camera has a web client, allowing it to be configured and controlled using a web browser from any device connected to the same local area network.

Web client Log In

Enter the IP address of the camera you wish to configure or control in the address field of the web browser of your choice, and press **Enter**. (The default IP address is **192.168.5.163**, but this was probably changed when the camera was configured. See page 37 to learn how to use NDI Studio Monitor to determine the current IP address of the camera.)

Log in to the web client:

User name: **admin**

Password: **admin**

The Admin user can preview, playback, configure and cancel actions in the web client.



Alternatively, you can log in as a normal user, which cannot change any configuration settings:

User name: **user1**

Password: **user1**

Download and Install Plug-in

The camera's web client uses an Adobe Flash plug-in to display a live preview of the camera video. Any time a new web browser is used to access the camera, this software must be installed to preview the video.

The first time a specific web browser is used to access the camera, the login page will display the message *"Playback plug-in is not installed, please download and install!"* Click on this message to download and install MRWebXinstall.exe, following the prompts.

Note: As of December 2020, the Chrome browser will not support the required Flash plugin, and as of that date a different browser must be used to view the video preview. All other control and configuration functions will continue to work in the Chrome browser.

Preview

Once logged into the web client, the user will see the video preview interface. In the preview screen users can control Pan, Tilt, Zoom, Focus, Video capture, and Sound. In addition, users can Set, Run and Delete Presets, among other operations.

Recording

Video can be saved to the local computer connected to the camera's web client. Click the Record button to begin recording, and click it again to stop recording. (See the Local Configuration settings on page 42 for instructions for setting the file save location.)

Playback

Video files can be played back after recording is completed. Click "Playback" to enter recording file and picture files playback page ,and then select the file "Video File" and click Search,and search out the video file. Click Play to play the video file.

Configuration

Click **Configuration** to open the device parameters setting page. The following options are available to the admin user: Local configuration, audio configuration, video configuration, network configuration, PTZ configuration, Internet access configuration, and system configuration.

Menu	Explanation
Local configuration	Video preview mode, record video packing time, and record video storage route settings.
Audio configuration	Audio compressing format, sampling frequency, sampling precision, and compression code rate settings.
Video configuration	Video encoding, video parameters, character-overlapping, character size, and video output settings.
Network configuration	Basic parameters, ethernet, DNS, and GB28181 settings.
System configuration	Equipment property, system time, user management, version update, factory reset, and reboot device settings.

Local Configuration

- **Video Preview Mode:** The User can choose real-time priority or fluency priority. The delay will be small when using real time priority mode and the fluency is good when under fluency priority mode. (Default values: real time normal (2), real time best (1), fluency normal (3), fluency good (4) and fluency best (5).)
- **Recording packing time (minute):** Set the recording video packing time (default is 10, the range is 1-120 minutes).
- **Recording/Snapshot file storage route:** Set local recording video/snapshot file storage location. The default location is D:\MyIPCam\. Click **Save** for the new settings to take effect.

Audio Configuration

- **Audio switch:** Choose to enable the audio or not.
- **Compression format:** Set the audio compression format. The device will reboot automatically after the change. (Default is MP3, with PCM and AAC options.)
- **Sampling frequency:** Once you set the sampling frequency the device will reboot automatically after the change. (Default is 44,100, with 16,000, 32,000 and 48,000 options.)
- **Sampling precision:** Set the sampling precision. (Default is 16bits.)
- **Compressing code rate:** Set the audio compression code rate. (Default is 64bits, with 32, 48, 96, 128bits options). Note: When clicking **SAVE**, it will remind "Enable has changed. Restart the device for the new setting to take effect after saving.

Video configuration

Video encoding

- **Code stream:** There are 2 different streams available. Use this to set which stream settings is being modified. (Options are main stream and secondary stream.)
- **Compression format:** Set the video compression format. (Default is H.264 for both streams.)
- **Profile:** Profile Mode Setting. (Default is HP, with BP and MP options.)
- **Video size:** Set video image resolution. When saving, reboot the camera for the new settings to take effect. (The main stream default is 1920 x 1080, with a 1280 x 720 option. The default secondary stream is 640 x 320, with 320 x 180, 1280 x 720, and 1920 x 1080 options.)
- **Stream rate control:** Set the rate control mode. (The primary / secondary stream default is variable bit rate, with fixed rate the other option.)
- **Image quality:** Set the image quality. Image quality can be changed only when the rate control is variable bit rate. (The default for the main stream is Better, while the default for the secondary stream is Not Good. Other options are Best, Better, Good, Bad, Worse, and Worst.)
- **Rate (Kb/s):** Set the video bit rate. (The main stream default is 4,096Kb/s, with a range of 64-12,288Kb/s possible. The secondary stream default is 1,024Kb/s, with 64-10,240Kb/s possible.)
- **Frame rate (F/S):** Set the video frame rate, in frames per second. (The default for both primary and secondary streams is 25 F/S, with possible values of 5-30 F/S.)
- **Key frame interval:** Set the key frame interval. (The default for both primary and secondary streams is 75 frames, with options of 1-150 frames.)

- **Stream name:** When streaming via RTSP or RTMP the user can modify the stream name. (Default name for the main stream is “live/av0”, and the secondary stream is “live/av1”.)

Stream Release

- **Switch:** To turn ON/OFF the Main/Secondary stream.
- **Protocol:** Primary/Secondary stream applies RTMP protocol.
- **Host Port:** Server port number. (Default is 1935, with possible values 0-65535.)
- **Host Address:** Server IP addresses. (Default is 192.168.5.11.)
- **Stream Name:** Choose a different stream name.
- **User:** Set the user name.
- **Password:** Set the password. Click Save for the new settings to take effect.

Method of obtaining the RTSP address: rtsp://<device IP address>:554/live/av0 (for the main stream; address for the secondary stream ends in av1).

RTP Broadcasting

- **Main/Sub Stream:** ON/OFF
- **Protocol:** RTP or TS
- **Address:** Defaults to 224.1.2.3, but can be changed.
- **Port:** Main Stream Default Port: 4000; Sub Stream Default Port: 4002
- **Visit:** Address comes up after setting, such as: rtp://224.1.2.3:4000 or udp://@224.1.2.3:4000

Video Parameters

Focus: Mode, range and sensitivity can be set.

- **Focus Mode:** Set the focus mode (defaults to Auto, with the other option Manual)
- **Focus range:** Set the focus range (defaults to Middle, with the options being Upper and Lower)
- **Focus Sensitivity:** Set the focus sensitivity (defaults to Low, with the other options being High and Medium)

Exposure: Mode, compensation, back light compensation, anti-flicker, gain limit, wide dynamic, shutter speed, aperture value and brightness can be set.

- **Exposure Mode:** Set the exposure mode. (Defaults to automatic. Other options are manual, shutter priority, aperture priority, and brightness priority.)
- **Exposure compensation:** Exposure compensation setting is active when it is auto status (default is off).
- **Exposure compensation value:** Set the exposure compensation value. Valid when Exposure Mode is set for auto (default is 0, with the range being -7 to 7).
- **BLC:** Set back light compensation. Valid when Exposure Mode is set to auto (default is off).
- **Anti-flicker:** Set up anti-flicker mode. Valid when Exposure Mode is automatic, aperture or brightness priority (defaults to 50Hz, with other options being Closed or 60Hz).
- **Gain limit:** Set the gain limits. Active when Exposure Mode is aperture or brightness priority (default is 3, with possible values of 0-15).
- **Dynamic range:** Set the dynamic range (default is 5, with possible values of 0-8).
- **Shutter speed:** Active when Exposure Mode is manual or shutter-priority (defaults to 1/100, with possible values ranging 1/25-/10,000).
- **Aperture value:** Set the aperture value. Active when Exposure Mode is manual or aperture-priority (defaults to F1.8, with possible values of Closed or ranging F11-F1.8).

- **Brightness:** Set the brightness value. Active when Exposure Mode is set to brightness priority (default 7, with possible values 0-23).

Color: White balance, saturation, color, white balance, sensitivity, color temperature, red gain and blue gain can be set.

- **White balance mode:** Set the white balance mode (default is Automatic, with other possible values being 3000K, 4000K, 5000K, 6500K, Manual, and One-push). Note: Click the “Correction” button when the white balance mode is set to One-push.
- **Saturation:** Set the saturation (default is 80%, with possible values ranging 60%-130%).
- **Auto white balance sensitivity:** Set the sensitivity for auto white balance (default is low, with other possible values high and medium).
- **Chroma:** Set the chrome (default is 7, with possible values ranging 0-14).
- **Color Temperature:** Set the color temperature (default is High, with other possible values being Low and Middle).
- **Red Gain:** Set the red gain. Setting is available when White Balance Mode is manual (default is 255, with possible values 0-255).
- **Blue Gain:** Set the Blue gain. Setting is available when White Balance Mode is manual (default is 199, with possible values 0-255).

Image: Brightness, contrast, sharpness, black and white mode, the gamma curve, Horizontal Flip and Vertical Flip can be set.

- **Brightness:** Set the brightness (default is 6, with possible values of 0-14).
- **Contrast:** Set the contrast (default is 8, with possible values 0-14).
- **Sharpness:** Set the sharpness value (default is 7, with possible values 0-15).
- **Black and white mode:** Set black and white mode (default is color, with black/white the other option).

- **Gamma:** Set gamma value setting (default is 0.45, with other options being 0.50, 0.52, and 0.55).
- **Flip Horizontal:** Set Flip Horizontal (default is Off).
- **Flip Vertical:** Set vertical flip (default is Off).

Noise Reduction: 2D noise reduction, 3D noise reduction and dynamic dead pixel correction available.

- **2D Noise Reduction:** Set 2D noise reduction level (default is Auto, with other possible values being 1-7 and Off).
- **3D Noise Reduction:** Set 3D noise reduction level (default is 5, with other possible values being 1-8 and Off).
- **Dynamic dead pixel correction:** Set Dynamic dead pixel correction (default is Off, with possible values 1-8).

Note: Click “Refresh” for the new settings to take effect.

Character-Overlapping

- **Display date and time:** Set whether to display the time and date (default is display).
- **Display Title:** Set whether to display the title (default is display).
- **Font Color of Time:** Set the font color of the date and time (default is white, with other options being black, yellow, red, and blue).
- **Font Color of Title:** Set the font color of the title (default is white, with other options being black, yellow, red, and blue).
- **Moving characters:** Set the display position of the moving date, time and title. Click the up, down, left, right buttons to move the corresponding character position.
- **Title Content:** Set title content (default is “CAMERA”).
- **Time Content:** Set time content (default is 1970/01/10 05:36:00).

Character Size

- **Main stream character size:** Set the character size of the display (default is 24, with 16 the other option).
- **Secondary stream character size:** Set the character size of the (default is 16, with 24 the other option).

Video output

- **Output Format:** Set the video output format (default is 1080p60, with other options being 1080p50, 1080p30, 1080p25, 1080i60, 1080i50, 720p60, 720p50, 720p30, 720p25, 1080p59.94, 1080i59.94, 1080p29.97, 720p59.94, and 720p29.97).

Network configuration

Network port

- **Data port:** Set the data port (default is 3000, with possible values 0-65535).
- **Web port:** Set the web port (default is 80, with possible values 0-65535).
- **Onvif port:** Set the Onvif port (default is 2000, with possible values 0-65535).
- **Soap port:** Set the Soap port (default is 1936, with possible values 0-65535).
- **RTMP port:** Set the RTMP port (default is 1935, with possible values 0-65535).
- **RTSP port:** Set the RTSP port (default is 554, with possible values 0-65535).
- **Visca port:** Set Visca port (default is 3001, with possible values 0-65535).
- **RTMP access:** rtmp://<equipment IP address>:1935/live/av0 (for main stream; end with av1 for second stream).

Ethernet parameters

- **DHCP:** Enable or disable “Obtain IP automatically” setting (default is Off).
- **IP address:** Set the IP address (default is 192.168.5.163). Note: This IP address is the same one used to login to the Web Client.
- **Subnet mask:** Set the subnet mask (default is 255.255.255.0).
- **Default gateway:** Set the default gateway (default is 0.0.0.0).
- **Physical address:** This parameter is read-only and cannot be modified.

DNS parameters

- **Preferred DNS server:** Set the preferred DNS server (default is 0.0.0.0).
- **Alternate DNS server:** Alternate DNS server settings (default is 0.0.0.0).

GB28181

This is a Chinese government standard for controlling video cameras remotely, similar to Onvif. This setting is not used outside of Mainland China.

System configuration

Device Properties

- **Device Name:** Set the device name (the default is Camera1).
- **Device ID:** Set the device ID (default is 1).
- **System Language:** Set the system language (default is Simplified Chinese , with English the other option). User will need to login again after changing the setting to see the new language.

System Time

- **Date Format:** Set the date format (YYYY-MM-DD is the default, with other options MM-DD-YYYY and DD-MM-YYYY).
- **Date separator:** Set the date separator (default is '/', with other options of '.' or '-').
- **Time Zone:** Set the time zone.
- **Time Type:** Set the time types (default is 24 hour time, with the other options being 12 hour).
- **Time setting:** Set time mode (to choose the computer time synchronization, NTP server time synchronization, or set manually).
- **Computer Time:** Set to synch the camera clock with the local connected computer.
- **Update interval:** Set the number of days between NTP server automatic updates. Valid if Time Setting is set to NTP server synchronization (default is 1, with other options ranging 2-10 days).
- **NTP server address or domain name:** Set NTP server address or domain name (default is time.nits.gov). Valid if Time Setting is set to NTP server synchronization.
- **NTP Server Port:** Sets the NTP server port (default 123). Valid if Time Setting is set to NTP server synchronization.
- **Set the time manually:** Available when Time Setting is Set Manually.

User Management

- **Select users:** Set the user type (the default is Administrator, with other options being Common User 1 and Common User 2).
- **User name:** Set the user name (select User Administrator default admin; select a common user1 default user1; to select a common user 2 default user2; user can modify their own).
- **Password:** Set a password. (Select User Administrator default admin; select a common user1 default user1; to select a common user 2 default user2; user can modify their own).
- **Password confirmation:** Confirmation of the password.

Note: Please note user name and password are case sensitive. If logged in as a User, one does not have privileges to configure preview, playback, or logoff.

Version upgrade

This screen displays the current version of the MCU, the camera, and the focus.

The camera firmware can be updated with new versions as required. The latest firmware can be found on the Glow Stream™ support website, at glowstream.io.

Update file: Click "Browse ..." installation, to select the upgrade file in the pop-up window. Click on the "Upgrade" button. The upgrade dialog will appear. The device will reboot automatically after the update is applied. Note: Make sure the power and network is connected during this process or the upgrade will fail.

Note: After the version upgrade is complete, you should restore factory defaults to ensure all new settings are available, by doing one of the following:

1. Through web client to restore the factory default configuration; IP accounts and passwords will be restored to the default settings.
2. Through the recovery menu
3. Using the remote control shortcut, * # 6.

Restore factory setting

Click on pop-up "Restore Factory Defaults" button and choose "yes" or "no". The device will restart automatically and restore factory settings.

Reboot

Click on the pop-up "Reboot" button and choose "yes" or "no". The device will restart automatically.

Logout

Select "Logout." Then choose "Yes" or "No" to confirm the logout.

External Interfaces

This section offers detailed descriptions of the various external interfaces and protocols used for controlling the camera. These interfaces include RS-232 input and output, RS-485 input, audio input, 3G-SDI output, HDMI output, ethernet port, and a DC 12V power port.

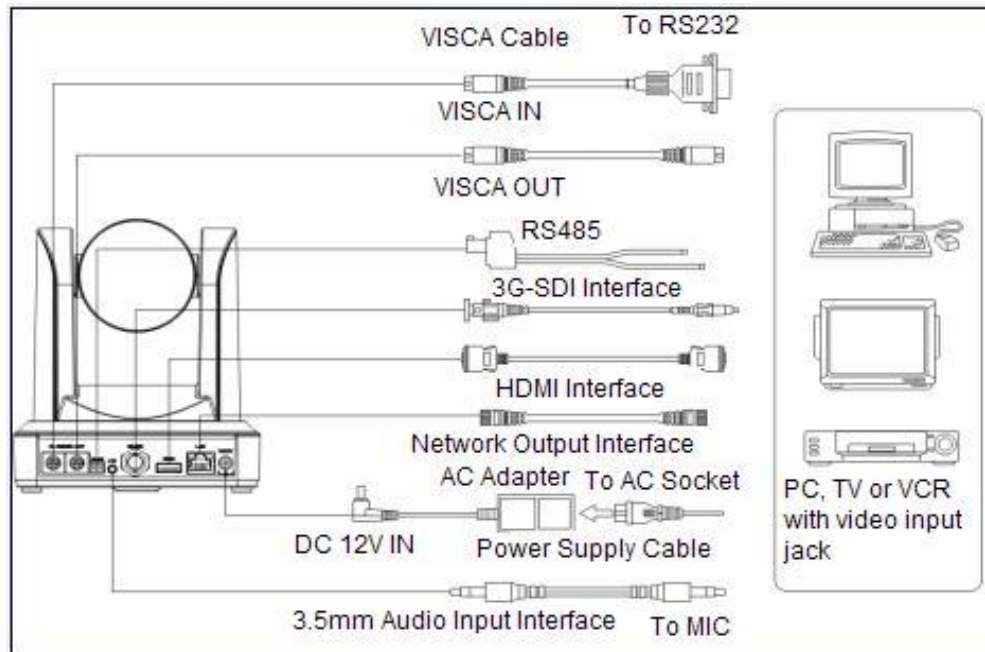

Bottom Dial Switch

Two DIP switches on the bottom of the camera are set to ON or OFF to select different modes of operation:

Mode	SW1	SW2	Description
1	OFF	ON	Working
2	ON	OFF	Updating

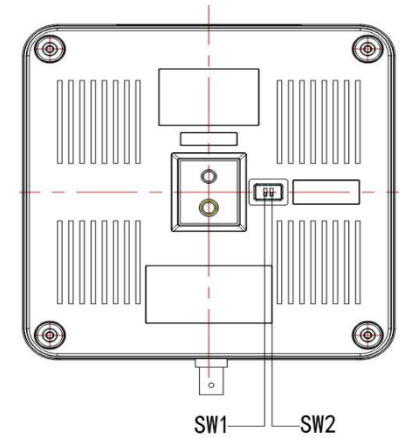

RS-232 Interface

The RS-232 ports are used for connecting remote control devices to the camera.

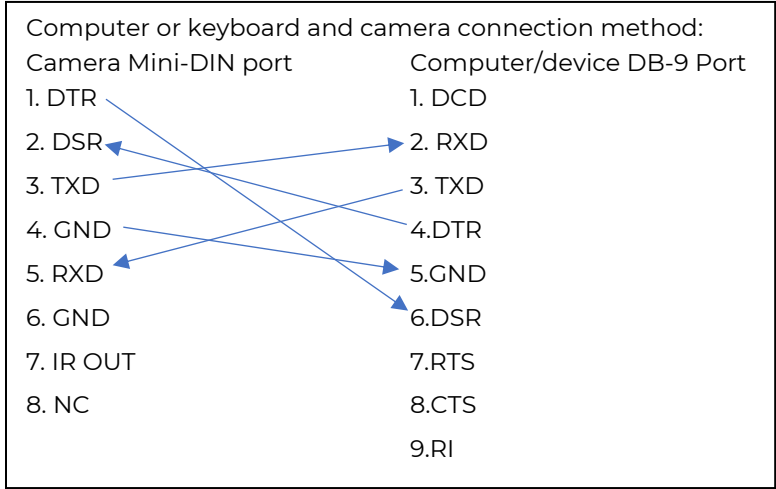
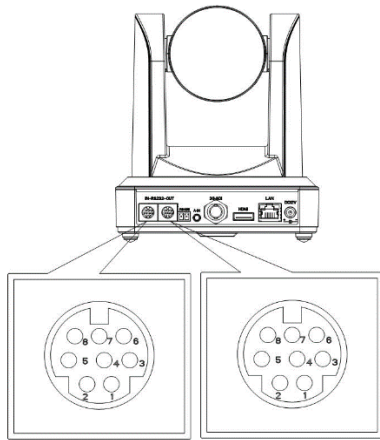

RS-232 Mini-DIN 8-Pin Port Definition

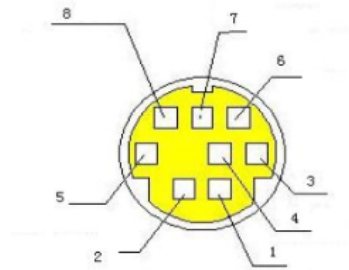

NO.	Port	Definition
1	DTR	Data Terminal Ready
2	DSR	Data Set Ready
3	TXD	Transmit Data
4	GND	System Ground
5	RXD	Receive Data
6	GND	System Ground
7	IR OUT	IR Commander Signal
8	NC	No Connection

RS-232 DB9 Port Definition

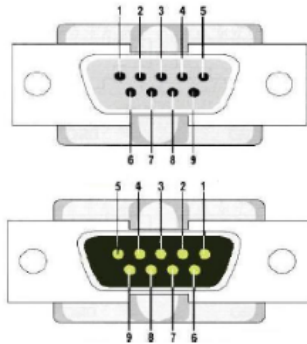

NO.	Port	Definition
1	DCD	Data Carrier Detect
2	RXD	Receive Data
3	TXD	Transmit Data
4	DTR	Data Terminal Ready
5	GND	System Ground
6	DSR	Data Set Ready
7	RTS	Request to Send
8	CTS	Clear to Send
9	RI	Ring Indicator

Visca Daisy-Chain Example

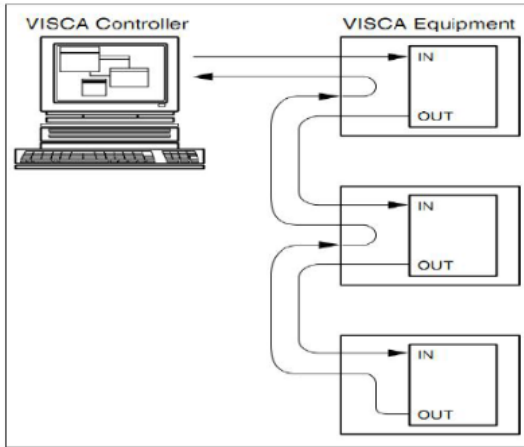

Camera cascade connection method

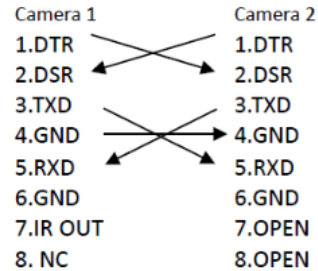

Serial Communication Control

Under normal conditions, the camera could be controlled through the RS-232 or RS-485 interface using the Visca protocol. The RS232C serial parameter are as follows:

- Baud rate: 2400/4800/9600/115200 bits/sec
- Start bit: 1
- data bits: 8
- Stop bit: 1
- Parity: None.

After the camera is powered on it will scan left then move back to the middle position. The self-test is finished after the zoom moves back and forth. (If position preset 0 was previously set, the camera will move to that position after initialization, rather than the middle position.) At this point, the user can control the camera by the serial commands.

VISCA protocol list

Camera return command

Ack/Completion Message		
	Command packet	Note
ACK	z0 41 FF	Returned when the command is accepted.
Completion	z0 51 FF	Returned when the command has been executed.

(z = camera address +8)

Error Messages		
	Command packet	Note
Syntax Error	z0 60 02 FF	Returned when the command format is different or when a command with illegal command parameters is accepted.
Command Not Executable	z0 61 41 FF	Returned when a command cannot be executed due to current conditions. For example, when commands controlling the focus manually are received during auto focus.

Camera control command

Command	Function	Command packet	Note
AddressSet	Broadcast	88 30 0p FF	P: Address setting
IF_Clear	Broadcast	88 01 00 01 FF	I/F Clear
CommandCancel		8x 21 FF	
CAM_Power	On	8x 01 04 00 02 FF	Power ON/OFF
	Off	8x 01 04 00 03 FF	
CAM_Zoom	Stop	8x 01 04 07 00 FF	
	Tele(Standard)	8x 01 04 07 02 FF	
	Wide(Standard)	8x 01 04 07 03 FF	
	Tele(Variable)	8x 01 04 07 2p FF	p = 0(low) - F(high)
	Wide(Variable)	8x 01 04 07 3p FF	
	Direct	8x 01 04 47 0p 0q 0r 0s FF	pqrs: Zoom Position
CAM_Focus	Stop	8x 01 04 08 00 FF	
	Far(Standard)	8x 01 04 08 02 FF	
	Near(Standard)	8x 01 04 08 03 FF	
	Far(Variable)	8x 01 04 08 2p FF	p = 0(low) - F(high)
	Near (Variable)	8x 01 04 08 3p FF	
	Direct	8x 01 04 48 0p 0q 0r 0s FF	pqrs: Focus Position
	Auto Focus	8x 01 04 38 02 FF	
	One Push Mode	8x 01 04 38 04 FF	
	Manual Focus	8x 01 04 38 03 FF	
CAM_Zoom Focus	Direct	8x 01 04 47 0p 0q 0r 0s 0t 0u 0v 0w FF	pqrs: Zoom Position tuvw: Focus Position
CAM_WB	Auto	8x 01 04 35 00 FF	
	3000K	8x 01 04 35 01 FF	

Command	Function	Command packet	Note
	4000k	8x 01 04 35 02 FF	
	One Push mode	8x 01 04 35 03 FF	
	5000k	8x 01 04 35 04 FF	
	Manual	8x 01 04 35 05 FF	
	6500k	8x 01 04 35 06 FF	
	3500K	8x 01 04 35 07 FF	
	4500K	8x 01 04 35 08 FF	
	5500K	8x 01 04 35 09 FF	
	6000K	8x 01 04 35 0A FF	
	7000K	8x 01 04 35 0B FF	
CAM_RGain	Reset	8x 01 04 03 00 FF	Manual Control of R Gain
	Up	8x 01 04 03 02 FF	
	Down	8x 01 04 03 03 FF	
	Direct	8x 01 04 43 00 00 0p 0q FF	pq: R Gain
CAM_Bgain	Reset	8x 01 04 04 00 FF	Manual Control of B Gain
	Up	8x 01 04 04 02 FF	
	Down	8x 01 04 04 03 FF	
	Direct	8x 01 04 44 00 00 0p 0q FF	pq: B Gain
CAM_AE	Full Auto	8x 01 04 39 00 FF	Automatic Exposure mode
	Manual	8x 01 04 39 03 FF	Manual Control mode
	Shutter priority	8x 01 04 39 0A FF	Shutter Priority Automatic Exposure mode
	Iris priority	8x 01 04 39 0B FF	Iris Priority Automatic Exposure mode
	Bright	8x 01 04 39 0D FF	Bright mode

Command	Function	Command packet	Note
CAM_Shutter	Reset	8x 01 04 0A 00 FF	Shutter Setting
	Up	8x 01 04 0A 02 FF	
	Down	8x 01 04 0A 03 FF	
	Direct	8x 01 04 4A 00 00 0p 0q FF	pq: Shutter Position
CAM_Iris	Reset	8x 01 04 0B 00 FF	Iris Setting
	Up	8x 01 04 0B 02 FF	
	Down	8x 01 04 0B 03 FF	
	Direct	8x 01 04 4B 00 00 0p 0q FF	pq: Iris Position
CAM_Gain Limit	Gain Limit	8x 01 04 2C 0p FF	p: Gain Positon
CAM_Bright	Reset	8x 01 04 0D 00 FF	Bright Setting
	Up	8x 01 04 0D 02 FF	
	Down	8x 01 04 0D 03 FF	
	Direct	8x 01 04 4D 00 00 0p 0q FF	pq: Bright Positon
CAM_ExpComp	On	8x 01 04 3E 02 FF	Exposure Compensation ON/OFF
	Off	8x 01 04 3E 03 FF	
	Reset	8x 01 04 0E 00 FF	Exposure Compensation Amount Setting
	Up	8x 01 04 0E 02 FF	
	Down	8x 01 04 0E 03 FF	
	Direct	8x 01 04 4E 00 00 0p 0q FF	pq: ExpComp Position
CAM_Back Light	On	8x 01 04 33 02 FF	Back Light Compensation
	Off	8x 01 04 33 03 FF	
CAM_WDRStrength	Reset	8x 01 04 21 00 FF	WDR Level Setting
	Up	8x 01 04 21 02 FF	

Command	Function	Command packet	Note
	Down	8x 01 04 21 03 FF	
	Direct	8x 01 04 51 00 00 00 0p FF	p: WDR Level Positon
CAM_NR (2D)		8x 01 04 53 0p FF	P=0-7 0:OFF
CAM_NR (3D)		8x 01 04 54 0p FF	P=0-8 0:OFF
CAM_Gamma		8x 01 04 5B 0p FF	p = 0 - 4 3: 0.52
			0: Default 4: 0.55
			1: 0.47
			2: 0.50
CAM_Flicker	OFF	8x 01 04 23 00 FF	OFF
	50HZ	8x 01 04 23 01 FF	50HZ
	60HZ	8x 01 04 23 02 FF	60HZ
CAM_Aperture	Reset	8x 01 04 02 00 FF	Aperture Control
	Up	8x 01 04 02 02 FF	
	Down	8x 01 04 02 03 FF	
	Direct	8x 01 04 42 00 00 0p 0q FF	pq: Aperture Gain
CAM_Memory	Reset	8x 01 04 3F 00 pq FF	pq: Memory Number(=0 to 254) Corresponds to 0 to 9 on the Remote Commander
	Set	8x 01 04 3F 01 pq FF	
	Recall	8x 01 04 3F 02 pq FF	
CAM_LR_Reverse	On	8x 01 04 61 02 FF	Image Flip Horizontal ON/OFF
	Off	8x 01 04 61 03 FF	
CAM_PictureFlip	On	8x 01 04 66 02 FF	Image Flip Vertical ON/OFF
	Off	8x 01 04 66 03 FF	
CAM_ColorSaturation	Direct	8x 01 04 49 00 00 00 0p FF	P=0-7 0:60% 1:70% 2:80% 3:90% 4:100%
CAM_IDWrite		8x 01 04 22 0p 0q 0r 0s FF	pqrs: Camera ID (=0000 to FFFF)

Command	Function	Command packet	Note																		
SYS_Menu	ON	8x 01 04 06 06 02 FF	Turn on the menu screen																		
	OFF	8x 01 04 06 06 03 FF	Turn off the menu screen																		
IR_Receive	ON	8x 01 06 08 02 FF	IR(remote commander)receive On/Off																		
	OFF	8x 01 06 08 03 FF																			
IR_ReceiveReturn	On	8x 01 7D 01 03 00 00 FF	IR(remote commander)receive message via the VISCA communication ON/OFF																		
	Off	8x 01 7D 01 13 00 00 FF																			
CAM_SettingReset	Reset	8x 01 04 A0 10 FF	Reset Factory Setting																		
CAM_Brightness	Direct	8x 01 04 A1 00 00 0p 0q FF	pq: Brightness Position																		
CAM_Contrast	Direct	8x 01 04 A2 00 00 0p 0q FF	pq: Contrast Position																		
CAM_Flip	OFF	8x 01 04 A4 00 FF	Single Command For Video Flip																		
	Flip-H	8x 01 04 A4 01 FF																			
	Flip-V	8x 01 04 A4 02 FF																			
	Flip-HV	8x 01 04 A4 03 FF																			
CAM_VideoSystem	Set camera video system	8x 01 06 35 00 0p FF	<table border="0"> <tr> <td>P: 0~E Video format</td> <td>8:720P30 9:720P25 A</td> </tr> <tr> <td>0:1080P60</td> <td>: 1080P59.94 B:</td> </tr> <tr> <td>1:1080P50</td> <td>1080i59.94 C:</td> </tr> <tr> <td>2:1080i60</td> <td>720P59.94</td> </tr> <tr> <td>3:1080i50</td> <td>1080P29.97 E:</td> </tr> <tr> <td>4:720P60</td> <td>720P29.97</td> </tr> <tr> <td>5:720P50</td> <td></td> </tr> <tr> <td>6:1080P30</td> <td></td> </tr> <tr> <td>7:1080P25</td> <td></td> </tr> </table>	P: 0~E Video format	8:720P30 9:720P25 A	0:1080P60	: 1080P59.94 B:	1:1080P50	1080i59.94 C:	2:1080i60	720P59.94	3:1080i50	1080P29.97 E:	4:720P60	720P29.97	5:720P50		6:1080P30		7:1080P25	
P: 0~E Video format	8:720P30 9:720P25 A																				
0:1080P60	: 1080P59.94 B:																				
1:1080P50	1080i59.94 C:																				
2:1080i60	720P59.94																				
3:1080i50	1080P29.97 E:																				
4:720P60	720P29.97																				
5:720P50																					
6:1080P30																					
7:1080P25																					
Pan_tiltDrive	Up	8x 01 06 01 VV WW 03 01 FF	VV: Pan speed 0x01 (low speed) to 0x18 (high speed) WW: Tilt speed																		

Command	Function	Command packet	Note
	Down	8x 01 06 01 VV WW 03 02 FF	0x01 (low speed) to 0x14 (high speed) YYYY: Pan Position ZZZZ: Tilt Position
	Left	8x 01 06 01 VV WW 01 03 FF	
	Right	8x 01 06 01 VV WW 02 03 FF	
	Upleft	8x 01 06 01 VV WW 01 01 FF	
	Upright	8x 01 06 01 VV WW 02 01 FF	
	DownLeft	8x 01 06 01 VV WW 01 02 FF	
	DownRight	8x 01 06 01 VV WW 02 02 FF	
	Stop	8x 01 06 01 VV WW 03 03 FF	
	AbsolutePosition	8x 01 06 02 VV WW 0Y 0Y 0Y 0Y 0Z 0Z 0Z 0Z FF	
	RelativePosition	8x 01 06 03 VV WW 0Y 0Y 0Y 0Y 0Z 0Z 0Z 0Z FF	
	Home	8x 01 06 04 FF	
Reset	8x 01 06 05 FF		
Pan-tiltLimitSet	Set	8x 01 06 07 00 0W 0Y 0Y 0Y 0Y 0Z 0Z 0Z 0Z FF	W:1 UpRight 0:DownLeft YYYY: Pan Limit Position(TBD) ZZZZ: Tilt Limit Position(TBD)

Command	Function	Command packet	Note
	Clear	8x 01 06 07 01 0W 07 0F 0F 0F 07 0F 0F 0F FF	
CAM_PowerInq	8x 09 04 00 FF	y0 50 02 FF	On
		y0 50 03 FF	Off(Standby)
CAM_ZoomPosInq	8x 09 04 47 FF	y0 50 0p 0q 0r 0s FF	pqrs: Zoom Position
CAM_FocusAFModelInq	8x 09 04 38 FF	y0 50 02 FF	Auto Focus
		y0 50 03 FF	Manual Focus
		y0 50 04 FF	One Push mode
CAM_FocusPosInq	8x 09 04 48 FF	y0 50 0p 0q 0r 0s FF	pqrs: Focus Position
CAM_WBModelInq	8x 09 04 35 FF	y0 50 00 FF	Auto
		y0 50 01 FF	3000K
		y0 50 02 FF	4000K
		y0 50 03 FF	One Push Mode
		y0 50 04 FF	5000K
		y0 50 05 FF	Manual
		y0 50 00 FF	6500K
		y0 50 06 FF	6500K
		y0 50 07 FF	3500K
		y0 50 08 FF	4500K
		y0 50 09 FF	5500K
		y0 50 0A FF	6000K
		y0 50 0B FF	7000K
CAM_RGainInq	8x 09 04 43 FF	y0 50 00 00 0p 0q FF	pq: R Gain
CAM_BGainInq	8x 09 04 44 FF	y0 50 00 00 0p 0q FF	pq: B Gain
CAM_AEModelInq	8x 09 04 39 FF	y0 50 00 FF	Full Auto
		y0 50 03 FF	Manual

Command	Function	Command packet	Note
		y0 50 0A FF	Shutter priority
		y0 50 0B FF	Iris priority
		y0 50 0D FF	Bright
CAM_ShutterPosInq	8x 09 04 4A FF	y0 50 00 00 0p 0q FF	pq: Shutter Position
CAM_IrisPosInq	8x 09 04 4B FF	y0 50 00 00 0p 0q FF	pq: Iris Position
CAM_Gain LimitInq	8x 09 04 2C FF	y0 50 0p FF	p: Gain Positon
CAM_BrightPosInq	8x 09 04 4D FF	y0 50 00 00 0p 0q FF	pq: Bright Position
CAM_ExpCompModelInq	8x 09 04 3E FF	y0 50 02 FF	On
		y0 50 03 FF	Off
CAM_ExpCompPosInq	8x 09 04 4E FF	y0 50 00 00 0p 0q FF	pq: ExpComp Position
CAM_BacklightModelInq	8x 09 04 33 FF	y0 50 02 FF	On
		y0 50 03 FF	Off
CAM_WDRStrengthInq	8x 09 04 51 FF	y0 50 00 00 00 0p FF	p: WDR Strength
CAM_NRLevel(2D) Inq	8x 09 04 53 FF	y0 50 0p FF	P: 2DNRLlevel
CAM_NRLevel(3D) Inq	8x 09 04 54 FF	y0 50 0p FF	P:3D NRLevel
CAM_FlickerModelInq	8x 09 04 55 FF	y0 50 0p FF	p: Flicker Settings(0: OFF,1: 50Hz,2:60Hz)
CAM_ApertureInq	8x 09 04 42 FF	y0 50 00 00 0p 0q FF	pq: Aperture Gain
CAM_PictureEffectModelInq	8x 09 04 63 FF	y0 50 00 FF	Off
		y0 50 04 FF	B&W
CAM_MemoryInq	8x 09 04 3F FF	y0 50 0p FF	p: Memory number last operated.
SYS_MenuModelInq	8x 09 06 06 FF	y0 50 02 FF	On
		y0 50 03 FF	Off
CAM_LR_ReverseInq	8x 09 04 61 FF	y0 50 02 FF	On
		y0 50 03 FF	Off
CAM_PictureFlipInq	8x 09 04 66 FF	y0 50 02 FF	On
		y0 50 03 FF	Off

Command	Function	Command packet	Note
CAM_ColorSaturationInq	8x 09 04 49 FF	y0 50 00 00 00 0p FF	p: Color Gain setting 0h (60%) to Eh (130%)
CAM_IDInq	8x 09 04 22 FF	y0 50 0p FF	p: Gamma ID
IR_ReceiveInq	8x 09 06 08 FF	y0 50 02 FF	On
		y0 50 03 FF	Off
IR_ReceiveReturn		y0 07 7D 01 04 00 FF	Power ON/OFF
		y0 07 7D 01 04 07 FF	Zoom tele/wide
		y0 07 7D 01 04 38 FF	AF ON/OFF
		y0 07 7D 01 04 33 FF	Camera _Backlight
		y0 07 7D 01 04 3F FF	Camera _Memery
		y0 07 7D 01 06 01 FF	Pan_titleDriver
CAM_BrightnessInq	8x 09 04 A1 FF	y0 50 00 00 0p 0q FF	pq: Brightness Position
CAM_ContrastInq	8x 09 04 A2 FF	y0 50 00 00 0p 0q FF	pq: Contrast Position
CAM_FlipInq	8x 09 04 A4 FF	y0 50 00 FF	Off
		y0 50 01 FF	Flip-H
		y0 50 02 FF	Flip-V
		y0 50 03 FF	Flip-HV
CAM_GammaInq	8x 09 04 5B FF	y0 50 0p FF	p: Gamma setting
CAM_VersionInq	8x 09 00 02 FF	y0 50 ab cd mn pq rs tu vw FF	ab cd : vender ID (0220) mn pq : model ID ST (0950) U3 (3950) rs tu : ARM Version vw : reserve
VideoSystemInq	8x 09 06 23 FF	y0 50 0p FF	P: 0~E Video format 0:1080P60 1:1080P50 2:1080i60 A : 8:720P30 9:720P25 E:

Command	Function	Command packet	Note
			1080P59.94 3:1080i50 B : 1080i59.94 4:720P60 C : 720P59.94 5:720P50 D : 1080P29.97 6:1080P30 720P29.97 7:1080P25
Pan-tiltMaxSpeedInq	8x 09 06 11 FF	y0 50 ww zz FF	ww: Pan Max Speed Speed zz: Tilt Max
Pan-tiltPosInq	8x 09 06 12 FF	y0 50 0w 0w 0w 0w 0z 0z 0z 0z FF	www: Pan Position Position zzzz: Tilt

Note: [X] in the above table indicates the camera address to be operated, [Y] = [x + 8]

Pelco-D protocol command list

Function	Byte1	Byte2	Byte3	Byte4	Byte5	Byte6	Byte7
Up	0xFF	Address	0x00	0x08	Pan Speed	Tilt Speed	SUM
Down	0xFF	Address	0x00	0x10	Pan Speed	Tilt Speed	SUM
Left	0xFF	Address	0x00	0x04	Pan Speed	Tilt Speed	SUM
Right	0xFF	Address	0x00	0x02	Pan Speed	Tilt Speed	SUM
Upleft	0xFF	Address	0x00	0x0C	Pan Speed	Tilt Speed	SUM
Upright	0xFF	Address	0x00	0x0A	Pan Speed	Tilt Speed	SUM

Function	Byte1	Byte2	Byte3	Byte4	Byte5	Byte6	Byte7
DownLeft	0xFF	Address	0x00	0x14	Pan Speed	Tilt Speed	SUM
DownRight	0xFF	Address	0x00	0x12	Pan Speed	Tilt Speed	SUM
Zoom In	0xFF	Address	0x00	0x20	0x00	0x00	SUM
Zoom Out	0xFF	Address	0x00	0x40	0x00	0x00	SUM
Focus Far	0xFF	Address	0x00	0x80	0x00	0x00	SUM
Focus Near	0xFF	Address	0x01	0x00	0x00	0x00	SUM
Set Preset	0xFF	Address	0x00	0x03	0x00	Preset ID	SUM
Clear Preset	0xFF	Address	0x00	0x05	0x00	Preset ID	SUM
Call Preset	0xFF	Address	0x00	0x07	0x00	Preset ID	SUM
Query Pan Position	0xFF	Address	0x00	0x51	0x00	0x00	SUM
Query Pan Position Response	0xFF	Address	0x00	0x59	Value High Byte	Value Low Byte	SUM
Query Tilt Position	0xFF	Address	0x00	0x53	0x00	0x00	SUM
Query Tilt Position Response	0xFF	Address	0x00	0x5B	Value High Byte	Value Low Byte	SUM
Query Zoom Position	0xFF	Address	0x00	0x55	0x00	0x00	SUM
Query Zoom Position Response	0xFF	Address	0x00	0x5D	Value High Byte	Value Low Byte	SUM

Pelco-P protocol command list

Function	Byte1	Byte2	Byte3	Byte4	Byte5	Byte6	Byte7	Byte8
Up	0xA0	Address	0x00	0x08	Pan Speed	Tilt Speed	0xAF	XOR
Down	0xA0	Address	0x00	0x10	Pan Speed	Tilt Speed	0xAF	XOR
Left	0xA0	Address	0x00	0x04	Pan Speed	Tilt Speed	0xAF	XOR
Right	0xA0	Address	0x00	0x02	Pan Speed	Tilt Speed	0xAF	XOR
Upleft	0xA0	Address	0x00	0x0C	Pan Speed	Tilt Speed	0xAF	XOR
Upright	0xA0	Address	0x00	0x0A	Pan Speed	Tilt Speed	0xAF	XOR

Function	Byte1	Byte2	Byte3	Byte4	Byte5	Byte6	Byte7	Byte8
DownLeft	0xA0	Address	0x00	0x14	Pan Speed	Tilt Speed	0xAF	XOR
DownRight	0xA0	Address	0x00	0x12	Pan Speed	Tilt Speed	0xAF	XOR
Zoom In	0xA0	Address	0x00	0x20	0x00	0x00	0xAF	XOR
Zoom Out	0xA0	Address	0x00	0x40	0x00	0x00	0xAF	XOR
Focus Far	0xA0	Address	0x01	0x00	0x00	0x00	0xAF	XOR
Focus Near	0xA0	Address	0x02	0x00	0x00	0x00	0xAF	XOR
Set Preset	0xA0	Address	0x00	0x03	0x00	Preset ID	0xAF	XOR
Clear Preset	0xA0	Address	0x00	0x05	0x00	Preset ID	0xAF	XOR
Call Preset	0xA0	Address	0x00	0x07	0x00	Preset ID	0xAF	XOR
Query Pan Position	0xA0	Address	0x00	0x51	0x00	0x00	0xAF	XOR
Query Pan Position Response	0xA0	Address	0x00	0x59	Value High Byte	Value Low Byte	0xAF	XOR
Query Tilt Position	0xA0	Address	0x00	0x53	0x00	0x00	0xAF	XOR
Query Tilt Position Response	0xA0	Address	0x00	0x5B	Value High Byte	Value Low Byte	0xAF	XOR
Query Zoom Position	0xA0	Address	0x00	0x55	0x00	0x00	0xAF	XOR
Query Zoom Position Response	0xA0	Address	0x00	0x5D	Value High Byte	Value Low Byte	0xAF	XOR

Maintenance

- Place the cover over the lens when camera is not in use, to prevent unnecessary build up of dust on the lens.
- Use soft cloth or tissue to clean the camera cover.
- Use a soft cloth to clean the lens. Use neutral cleanser if really dirty. Do not use a strong or corrosive cleanser, avoiding scuffing.
- If camera will not be used for an extended period of time, unplug the camera from power.

Troubleshooting

My camera won't power on

If you are trying to use Power-over-Ethernet:

1. Make sure the network switch supports PoE
2. Make sure the network switch is powered on
3. Make sure the total power draw of all connected devices does not exceed the power capacity of the PoE network switch

If you are trying to use DC power:

1. Make sure the DC adapter is plugged in
2. Make sure you are using an adapter with the correct power rating, and correct polarity

My computer won't connect to the camera

1. Make sure the camera is powered on
2. Make sure the network cable is not bad
3. Make sure the computer and camera IP addresses are in the same network
4. If connecting directly (without a network switch), make sure you are using a crossover cable
5. If the camera's IP address has been changed and you want to reset it, this can be done using the infrared remote. Press these buttons in this sequence: [*] [#] [MANUAL]

Sometimes there is no image

Check for issues in your video cable.

Image shakes when zooming in or out

1. Confirm the camera installation position is solid.
2. Check for shaking of the camera or other objects near the camera.

Remote control does not work

1. Remote control address is set to 1 (if the machine is set back to the factory defaults, remote control addresses need to be back to 1 too)
2. Check the battery in the remote control.
3. Check the camera's bottom dial switches to ensure the camera is in working mode (see page 54).
4. Confirm that the menu is closed. The camera PTZ controls only work through remote controller when the menu is closed. (Please note, the menu is not be displayed on the NDI video output. The menu will automatically exit after 30 seconds, then the camera can be controlled again by remote controller.)

Serial port does not work.

1. Check whether the camera serial device protocol, baud rate, and address are consistent
2. Check whether the control cable is connected properly
3. Check the camera's bottom dial switches to ensure the camera is in working mode (see page 54).

There is high latency in vMix

Latency should be 80-160 ms. If it is higher, try setting the frame rate to 60 to decrease video latency, and ensure you are using progressive scan, not interlaced

The video freezes when using the NDI stream

If the video stutters or freezes, this may be due to network issues. For best network performance:

1. Use a separate network for your video system, to minimize network traffic
2. Avoid using wireless WiFi connections in your network, because radio interference can reduce network performance

How much bandwidth does NDI|HX use?

Bitrate:	Bitrate (mbps)	Resolution	Frame Rate
Lowest	0-6	640×360	30fps
Low	7-8	1280×720	60fps
Medium	9-12	1920×1080	30fps
High	13-22	1920×1080	60fps

Limited Warranty

Glow Stream LLC (the “Company”) warrants this product against defects in material or workmanship for the time periods and as set forth below. Pursuant to this Limited Warranty, the Company will, at its option, (i) repair the product using new or refurbished parts or (ii) replace the product with a new or refurbished product. For the purposes of this Limited Warranty, “refurbished” means a product or part that has been returned to its original specifications. **In the event of a defect, these are your exclusive remedies.**

Term: For a period of one (1) year from the original date of purchase of the product, Glow Stream will, at its option, repair or replace with new or refurbished product or parts, any product or parts determined to be defective. This period is extended by six (6) months if the Company is notified of the purchase within ninety (90) days of purchase by registering the product with the Company.

This Limited Warranty covers only the hardware components packaged with the Product. It does not cover technical assistance for hardware or software usage and it does not cover any software products whether or not contained in the Product; any such software is provided “AS IS” unless expressly provided for in any enclosed software Limited Warranty. Please refer to the End User License Agreements included with the Product for your rights and obligations with respect to the software.

Instructions: To obtain warranty service, you must deliver the product, freight prepaid, in either its original packaging or packaging affording an equal degree of protection to the Company’s authorized

service facility specified. **It is your responsibility to backup any data, software or other materials you may have stored or preserved in your unit. It is likely that such data, software, or other materials will be lost or reformatted during service and the Company will not be responsible for any such damage or loss.** A dated purchase receipt is required. For specific instructions on how to obtain warranty service for your product,

Visit Glow Stream's Web Site:
glowstream.io

Or call the Glow Stream customer support phone number
1-800-297-9071

Repair / Replacement Warranty: This Limited Warranty shall apply to any repair, replacement part or replacement product for the remainder of the original Limited Warranty period or for ninety (90) days, whichever is longer. Any parts or product replaced under this Limited Warranty will become the property of the Company.

This Limited Warranty only covers product issues caused by defects in material or workmanship during ordinary use; it does not cover product issues caused by any other reason, including but not limited to product issues due to acts of God, misuse, limitations of technology, or modification of or to any part of the product. This Limited Warranty does not cover Company products sold AS IS or WITH ALL FAULTS or consumables (such as fuses or batteries). This Limited Warranty is invalid if the factory-applied serial

number has been altered or removed from the product. This Limited Warranty is valid only in the United States.

LIMITATION OF DAMAGES: THE COMPANY SHALL NOT BE LIABLE FOR ANY INCIDENTAL OR CONSEQUENTIAL DAMAGES FOR BREACH OF ANY EXPRESS OR IMPLIED WARRANTY ON THIS PRODUCT.

DURATION OF IMPLIED WARRANTIES: EXCEPT TO THE EXTENT PROHIBITED BY APPLICABLE LAW, ANY IMPLIED WARRANTY OF MERCHANTABILITY OR FITNESS FOR A PARTICULAR PURPOSE ON THIS PRODUCT IS LIMITED IN DURATION TO THE DURATION OF THIS WARRANTY.

Some states do not allow the exclusion or limitation of incidental or consequential damages, or allow limitations on how long an implied warranty lasts, so the above limitations may not apply to you. This Limited Warranty gives you specific legal rights and you may have other rights which vary from state to state.

Get the latest software updates online
at glowstream.io.

GL^{OW} STREAM™
glowstream.io